

MDA800 Series Motor Drive Analyzers



Key Features

- Complete Motor Drive System Debug and Validation in One Instrument
- Three-Phase Power Measurements; Real, Apparent, Reactive Power
- Efficiency Measurements
- User-Configurable Power Table
- Two- and Three-Wattmeter Methods Supported
- Per-Cycle Time-Correlated Waveforms From Power Values
- Dynamic Drive Response Analysis, From Startup To Overload
- Unique Zoom+Gate Mode
- Line-Line To Line-Neutral Voltage Conversion
- 1000 V_{RMS} Isolation with HVD Series Differential Probes
- Easily Interface Other Current Measurement Devices
- Complete Motor Integration (Torque, Speed, Position)
- Flexible Setup Capability
- Graphical User Interface

Motor Drive Analyzers provide complete three-phase power analysis from motor drive input through motor mechanical output, with results in a convenient Numeric table format. Motor speed, position, and torque integration are the most complete available. Long memory, per-cycle “synthesized” Waveforms and Zoom+Gate mode provide powerful dynamic drive and motor analysis. 8 analog input channels (MSO optional) with high resolution (12-bits), sample rate (up to 2.5 GS/s), bandwidth (up to 1 GHz) and memory (up to 250 Mpt/ch) provide unique capability to perform complete system debug on the motor drive power section, motor mechanical performance, and embedded drive control system operation.

Complete Drive System Debug

The Motor Drive Analyzer acquires drive power section, power transistor, and embedded control system signals, and performs three-phase power analysis of the power section waveforms. Correlation of drive system behaviors to embedded control loop signals enables debug and analysis of all aspects of the complete motor drive.

Numerics Measurement Table

Various voltage, current, power (real, apparent, and reactive), phase angle/ power factor, and efficiency parameters are calculated on acquired voltage and current waveforms and displayed in a table. The table is displayed along with the acquisition waveforms.

Zoom+Gate Dynamic Analysis

Capture long acquisitions and Zoom+Gate with instant table value updates and views of dynamic three-phase power and motor drive performance.

Most Complete Motor Mechanical Integration

Simple integration is provided for nearly any type of speed, rotation or position sensor, including analog and digital (pulse) tachometers, Brushless DC (BLDC) Hall sensor, Quadrature Encoder Interface (QEI), and Resolvers. Additionally, Hall sensor and QEI signals can be integrated through digital inputs, preserving valuable analog input channels for other signals.

THE MOTOR DRIVE ANALYZER – A NEW CLASS OF INSTRUMENT

Instrument Evolution

The increasing speed, size, and complexity of three-phase power electronics and drives systems calls for new instrument paradigms that can acquire any drive or motor signal and perform any debug, validation or analysis on the complete drive system, including three-phase power and efficiency calculations.

That new instrument is the Teledyne LeCroy Motor Drive Analyzer. It has capabilities that previously required multiple instruments.

The Motor Drive Analyzer has the bandwidth (1 GHz at 2.5 GS/s), inputs (8 analog channels + 16 optional digital channels), acquisition memory (50 Mpts/ch standard, up to 250 Mpts/ch optional) to acquire any signal, from high-speed embedded control signals to low-speed mechanical signals, and the power system signals in between. Then,

it performs three-phase and mechanical power analysis beyond what a power analyzer instrument can do. One acquisition system means one result on one display, and faster understanding.



Motor Drive Analyzer Complete Capability

Power analyzers perform a single function, and have their place as a “golden-reference” power measurement device. But they are limited to steady-state analysis and provide simple “black-box” analysis. 4 channel and/or 8-bit oscilloscopes are good for basic embedded control debug and validation, but they lack enough inputs for complex drive system and control loop analysis, and don’t have enough resolution to precisely measure power and efficiency values.

The Motor Drive Analyzer has none of these limitations, can acquire any analog, digital, serial data, or power signal and perform complex three-phase power calculations and dynamic drive and control loop analysis.

Power Analyzer Test Coverage

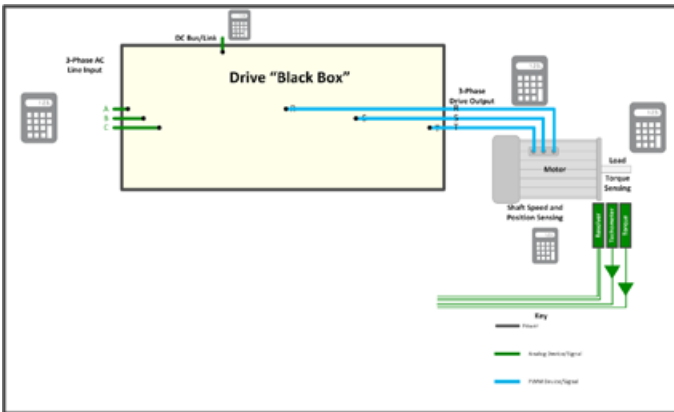

4 Channel and 8-bit Oscilloscope Test Coverage

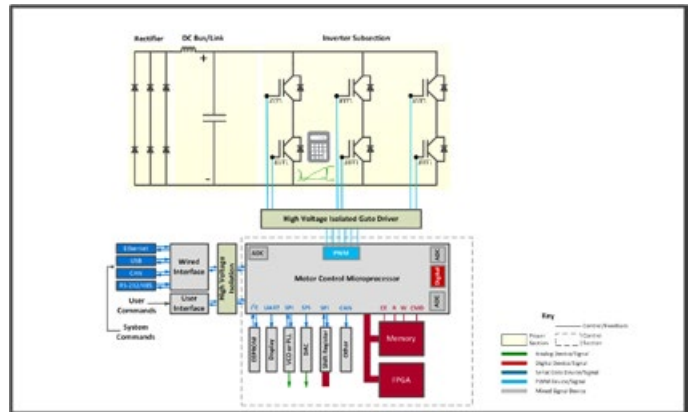

Teledyne LeCroy Motor Drive Analyzer Test Coverage

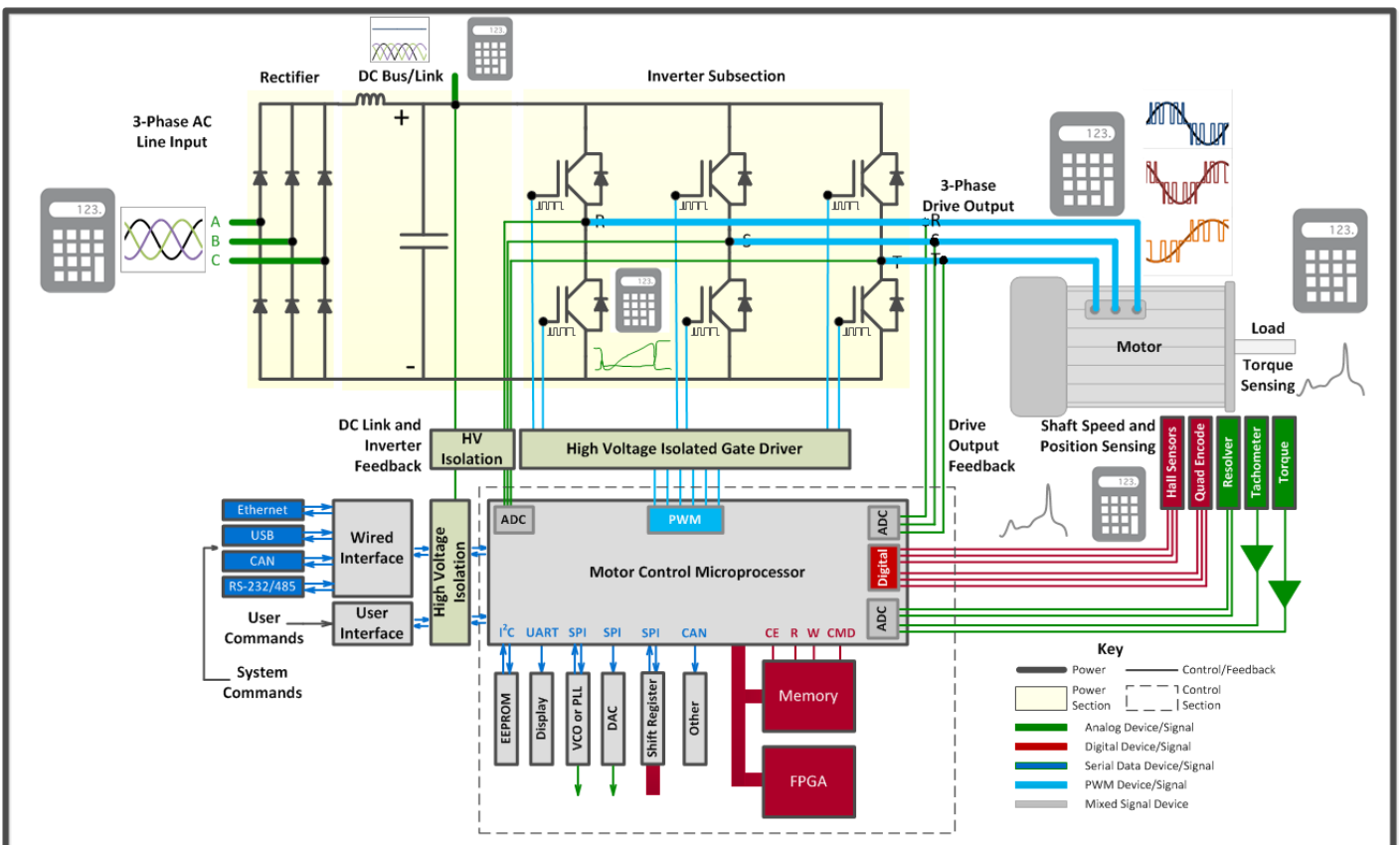

MORE CAPABILITY THAN YOU EVER IMAGINED WAS POSSIBLE

The Motor Drive Analyzer provides an extensive range of capabilities to allow you to debug your three-phase power electronics or motor drive design faster than ever before. Don't limit yourself to one screen – attach a UHD (4k) monitor and create a larger palette to perform your analysis on.

1. Zoom+Gate Mode

Take a single long acquisition of a dynamic event, and with the press of one button, zoom through the waveforms and gate the measurement results to the zoomed area. Change the zoom position and the measurement tables and per-cycle “synthesized” Waveforms update instantly. Gain faster understanding of dynamic drive and motor behaviors.

2. Comprehensive Speed Integration

Supports Hall sensors, Quadrature Encoder Interface (QEI) and Resolver interface for speed calculations

3. Numerics Table

User-definable and quickly summarizes the mean value for the entire acquisition

4. Touch to Learn

Simply touch a measurement and a per-cycle “synthesized” Waveforms is created showing the change in that measurement over time





5. Vertical Zooming

Capture then vertically zoom for detail, as shown here in the DC bus voltage and current signals

6. Q-Scape Displays

Use Q-Scape multi-tabbed displays to organize waveforms onto separate tabs, then view them all at once, or one tab at a time

7. Statistics Table

Displays the complete measurement set statistical data for any Numerics table measurement

8. Per-cycle “Synthesized” Waveforms

Enhances and speeds understanding of complex behaviors. Note the red trace (Torque) clearly shows torque ripple behaviors.

9. Multi-Stage Power Analysis with Efficiency

Calculated stage-stage and overall (cumulative) efficiency independently for greater understanding

10. Cursors

Place a cursor on any waveform and get an instantaneous reading of drive behavior

11. XY Displays

Up to 12 different XY displays on up to 8 different XY grids, or conventional grids

Numerics Measurement Table

Like a power analyzer, a user-configurable table is provided for display of a selection of power (real, apparent, reactive), power factor, phase angle, efficiency, voltage, current or motor mechanical parameters. Up to 120 values total may be displayed in 10 rows and 12 columns for any selection of input or output individual phase or total three-phase,

DC bus/link, or motor mechanical values. Efficiency, slip, and rotor angle may also be displayed.

The numeric values displayed are mean values from a statistical data set that is calculated on a “per-cycle” basis using a user-defined synchronization source signal. This display corresponds to what is normally provided by a dedicated power analyzer instrument.

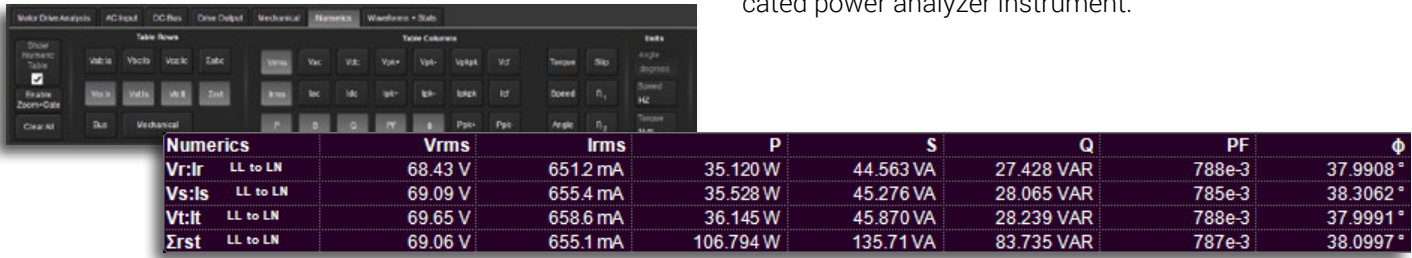

This two second capture shows the drive output waveforms on the left and the Torque, Speed and Mechanical Power Waveform per-cycle values over time are shown to the right.

Per-cycle “Synthesized” Waveforms

A single averaged value “hides” dynamic behaviors. Simply “touch” the value in the Numerics table and a detailed per-cycle Waveform will be created from the complete per-cycle measurement set and then automatically displayed time-correlated to the original acquisition or zoomed areas of the acquisition. Statistical values (min, max, number, etc.) can also be displayed. Use this advanced capability to correlate complex drive behaviors to other control or power system waveforms, and to debug drive system problems. This capability is not provided in any Power Analyzer instrument.

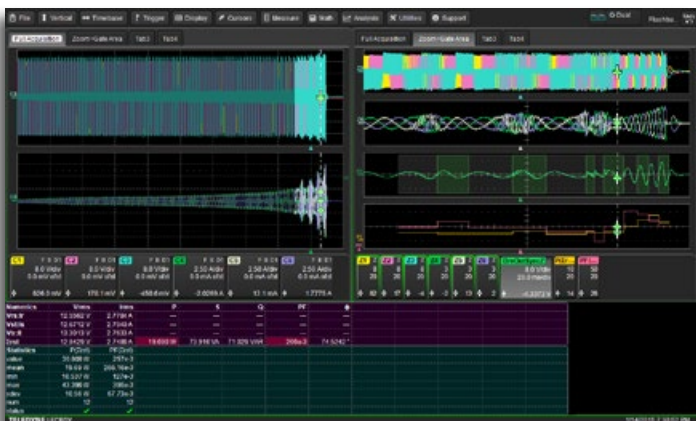

Zoom+Gate Mode

Enable Zoom+Gate mode to create zooms of all channel acquisitions and gate the Numerics and Statistics measurement tables to the zoomed area. Per-cycle displayed Waveforms will be zoomed and time-correlated to the other Zoomed waveforms. Change the zoom location and size and the data will instantly update. Scroll quickly through your measurement set to gain fast and deep insight into drive and control system behaviors.

Dynamic Drive Response

The long acquisition memory in the Motor Drive Analyzers (up to 250 Mpts/Ch) provides unique capabilities for motor and drive dynamic response analysis. For example, 25 seconds of continuous acquisition capture is possible at a sample rate of 10 MS/s. This permits complete understanding of dynamic drive behaviors, such as startup, application of load, or fast changing load conditions, and correlation of drive response problems to control system instructions or power section failures.



This 480V drive has 10 second acquisitions for the AC Input and Drive Output (on the left) and on the right are shown power, efficiency and power factor Waveforms over time.

Motor Mechanical Integration

The combination of 8 analog and 16 digital inputs (optional) in the Motor Drive Analyzers provides more motor integration capability than a power analyzer instrument. For instance, not only can standard analog and digital (pulse) tachometers be integrated for speed sensing, but analog Resolvers, digital Quadrature Encoder Interface and Brushless DC Hall Sensors may also be used to provide speed, direction, and absolute position information, not normally possible with a power analyzer.

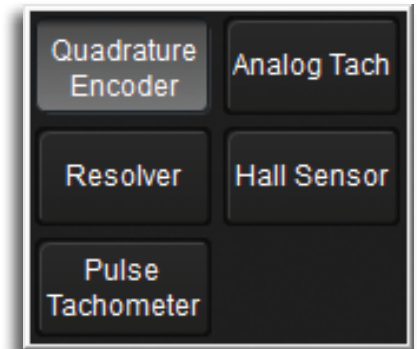

Flexible Setup Capability

The eight analog input channels provide capability for direct measurement of three voltage and three current signals from an AC Line input or Drive Output. However, support is also provided for a two-wattmeter measurement method for three-phase power, which allows three-phase measurements to be made using two voltage and two current

signals. Therefore, input/output efficiency measurements of a complete drive can be performed using the eight analog input channels. Support is also provided for a Line-Line to Line-Neutral voltage conversion so as to allow intuitive line-line probing with per-phase line-neutral reported results.

Motor Drive Analyzer Capabilities

Setup Capability

Measurement Locations	AC Input, DC Bus (Link), Drive Output, Mechanical Output
Wiring Configurations	AC Input: 1-phase / 2-wire (1V1A); 1-phase / 3-wire (2V/2A); 3-phase / 3-wire (2V2A); 3-phase / 3-wire (3V3A); 3-phase / 4-wire (3V3A); None DC Bus: 1-phase / 2-wire (1V1A); None Drive Output: 1-phase / Half-Bridge (1V1A); 1-phase / Full-Bridge (1V1A); 3-phase / 3-wire (2V2A); 3-phase / 3-wire (3V3A); 3-phase / 4-wire (3V3A); None
Sync (per-cycle) Measurement Signal	Independently settable for AC Input, DC Bus, Drive Output and Mechanical Output. Low pass filter (LPF) cutoff settable from 20 Hz to 1 MHz. Hysteresis settable from 0-100% full amplitude. Source can be any input analog channel, memory trace, or math function.
Voltage Measurement Method	Line-Line or Line-Neutral (with L-L to L-N conversion supported)
Calculation Waveform Sources	Any input channel or stored memory trace

Numerics Measurement Table Selections (Per-cycle Calculated, Mean Value Displayed)

Voltage	RMS voltage, AC Voltage, DC Voltage, Peak Positive Voltage, Peak Negative Voltage, Peak-Peak Voltage, Voltage Crest Factor
Current	RMS Current, AC Current, DC Current, Peak Positive Current, Peak Negative Current, Peak-Peak Current, Current Crest Factor
Power & Efficiency	Real, Apparent, and Reactive Power, Peak Positive Real Power, Peak Negative Real Power, Power Factor, Phase Angle, Incremental Efficiency, Total Efficiency
Motor Mechanical + Other	Torque, Speed, Angle (as defined by sensor, or adjusted with Offset Angle setting), Mechanical Power, AC induction motor Slip
Source Selections	Voltage: Va, Vb, Vc, Va-b, Vb-c, Vc-a, Vr, Vs, Vt, Vr-s, Vs-t, Vt-r, Ia, Ib, Ic, Ir, Is, It, Vbus, Ibus, Mechanical. Up to 10 rows (sources) and 12 columns (measurements) may be displayed in the table at any time. Source selections dependent on Wiring Configuration selections and Line-Line to Line-Neutral selections.

Motor Mechanical Integration

Speed + Direction	Analog Tachometer (0-xVdc = speed). Source is analog input. Digital Tachometer (x pulse/revolution = speed). Source may be digital or analog input. Hall Sensors (three digital inputs). Source may be digital or analog input.
Speed + Direction + Position	Resolver. Source is two or three analog inputs. Quadrature Encoder Interface (QEI) (A, B, and Z input). Source may be digital or analog input.
Torque	0-xVdc = Torque mV/V type

Per-cycle "Synthesized" Waveforms and Statistics

Waveforms	A time-correlated waveform of any per-cycle Numerics Table measurement parameter may be created and displayed anywhere on the grid. Up to 12 detailed per-cycle Waveforms may be displayed at one time, with up to 40 waveforms total (channels, memories, zooms, math, and per-cycle Waveforms) displayed at any one time.
Statistics	Detailed statistics on up to 12 per-cycle Numerics Table measurement parameters may be displayed at one time.

Zoom+Gate Mode

Operation	Press "Zoom+Gate" button to create zooms of all voltage, current and mechanical signals (analog or digital) and simultaneously gate the Numerics and Statistics tables to the zoomed area. Displayed per-cycle "synthesized" Waveforms are simultaneously time-correlated to the zoomed area. Scroll through the full acquisition using Zoom position and ratio (size) controls and view instantaneous updates of table values.
-----------	---

Typical Accuracy

Voltage, Current and Power	Typically within 1%, depending on voltage and current measurement device. Recommended voltage probe (line-line voltage sensing) = Teledyne LeCroy HVD Series HV Differential Probe Recommended voltage probe (line-neutral voltage sensing) = Teledyne LeCroy HVD Series HV Differential Probe (1000Vrms isolated) for voltages >50Vrms, Teledyne LeCroy passive probe (Qty. 4 included) for voltages ≤50Vrms Recommended current probes = Teledyne LeCroy CP Series Current Probes Other voltage and current measurement devices may be integrated into the oscilloscope and motor drive power analysis software.
----------------------------	--

Available Options & Accessories

Acquisition Memory	100 Mpt/ch (HDO8k-L) and 250 Mpt/ch (HDO8k-XL)
MSO Option	16 digital input capability (HDO8k-MSO)

Consult HDO8000 datasheet for full range of options, accessories and probes

Customer Service

Teledyne LeCroy oscilloscopes and probes are designed, built, and tested to ensure high reliability. In the unlikely event you experience difficulties, our digital oscilloscopes are fully warranted for three years and our probes are warranted for one year. This warranty includes:

- No charge for return shipping
- Long-term 7-year support
- Upgrade to latest software at no charge



1-800-5-LeCroy
teledynelecroy.com

Local sales offices are located throughout the world.
Visit our website to find the most convenient location.